

A16 Planfräser *Face mills, Fraises à surfer, Frese a spianare*

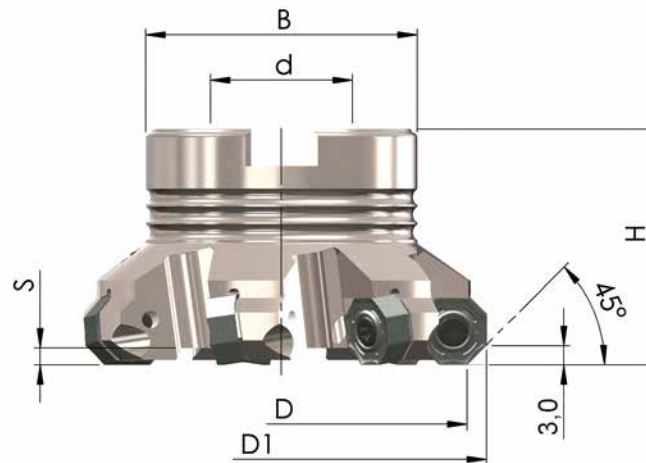

Aufsteckfräser *Shell type mills, Fraises à alésage, Frese per attacco a manicotto*



Bestell-Nr. <i>Order-No., Référence, Codice</i>	D	D ₁	H	d	B	S	Z	MS
45PP-040-538-4	40	47,4	40	22	38	2,9	4	MS-10x25-912
45PP-050-538-5	50	57,4	40	22	46	2,9	5	MS-10x25-912
45PP-063-538-5	63	70,4	40	22	46	2,9	5	MS-10x25-912
45PP-080-538-6	80	87,4	50	27	58	2,9	6	MS-12x30-912
45PP-100-538-9	100	107,4	50	32	78	2,9	9	MS-16x30-912
45PP-125-538-10	125	132,4	63	40	90	2,9	10	MS-20x55-7991
Enge Teilung <i>close pitch, à pas réduit, a passo stretto:</i>								
45PP-040-538-5	40	47,4	40	22	38	2,9	5	MS-10x25-912
45PP-050-538-6	50	57,4	40	22	46	2,9	6	MS-10x25-912
45PP-063-538-7	63	70,4	40	22	46	2,9	7	MS-10x25-912
45PP-080-538-9	80	87,4	50	27	58	2,9	9	MS-12x30-912
45PP-100-538-11	100	107,4	50	32	78	2,9	11	MS-16x30-912
45PP-125-538-13	125	132,4	63	40	90	2,9	13	MS-20x55-7991

MS= Mittenschraube *Central screw, Vis centrale, Vite centrale di fissaggio*

A16 Planfräser *Face mills, Fraises à surfer, Frese a spianare*



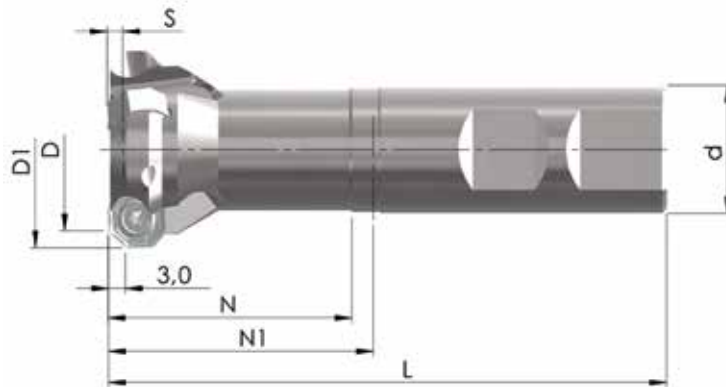







Schafffräser DIN 1835-B *Shank type mills, Fraises à queue Weldon, Frese a gambo Weldon*



Bestell-Nr. Order-No., Référence, Codice	D	D ₁	N	N ₁	L	d	S	Z
45PP-20-20-538-2	20	27,4	32	48	100	20	2,9	2
45PP-25-25-538-2	25	32,4	32	42	100	25	2,9	2
45PP-32-25-538-3	32	39,4	48	52	110	25	2,9	3
45PP-32-32-538-3	32	39,4	48	48	110	32	2,9	3
Enge Teilung <i>close pitch, à pas réduit, a passo stretto:</i>								
45PP-25-25-538-3	25	32,4	32	42	100	25	2,9	3

A16 Fräswendepplatten und Schnittdaten

Milling inserts and parameters, Plaquettes de fraiseage et paramètres, Inserti e parametri di taglio

			HC45 (code 41)	HT45 (code 31)	HT32 (code 33)	HC30 (code 52)	XC35 (code 46)	HT20 (code 32)	
	JMA16-538- IK 11,4x5,2  	Order- No.		A16A-DN31	A16A-CL33			A16A-BD32	
	f_z [mm]			0,15 (0,10-0,30)	0,15 (0,10-0,30)			0,20 (0,15-0,50)	
	JMA16-738- IK 11,4x5,2  	Order- No.	A16B-DR41			A16B-CP52	A16B-ES46		
	f_z [mm]		0,15 (0,10-0,30)			0,15 (0,10-0,30)	0,15 (0,10-0,30)		
	JMA16-838- IK 11,4x5,2  	Order- No.		A16B-HW31	A16B-GU33			A16B-FT32	
	f_z [mm]			0,15 (0,10-0,30)	0,15 (0,10-0,30)			0,20 (0,15-0,50)	
			20	20	20	20	20	20	

V_c [m/min]	Stahl Steel Acier Acciaio	Rostfrei Stainless Acier inoxydable Inossidabile	Guss Cast iron Fonte Ghisa	NE-Metalle Non-ferrous metals Non ferreux Metalli non ferritici	Hochwarmfest Highly heat-resistant Superalliages Resistente al calore	Gehärtet Tempered Aciers traités Temprato
HC45	250 (200 - 350)	240 (140 - 300)	240 (130 - 280)			
HT45	250 (200 - 350)	240 (140 - 300)	240 (130 - 280)			
HT32	250 (200 - 350)	240 (140 - 300)			60 (40 - 200)	
HC30	160 (120 - 220)	200 (100 - 300)			60 (40 - 200)	
XC35	120 (60 - 120)	100 (60 - 180)			80 (40 - 200)	
HT20			260 (180 - 350)			80 (40 - 120)

Ersatzteile Spare parts, Pièces de rechange, Parti di ricambio

	SS 3,5-2 (M = 2,3-2,5 Nm)		T 15		Fett Grease, Graisse, Grasso
---	-------------------------------------	---	-------------	---	--